

# Clarice®

## WOODWORKER



### WOODEN WORKBENCH

MODEL NO: CH1500B

PART NO: 6500129

### ASSEMBLY INSTRUCTIONS

ORIGINAL INSTRUCTIONS

GC 03-24

# INTRODUCTION

Thank you for purchasing this CLARKE product.

Please read these instructions carefully in order to ensure that the workbench is assembled correctly, thereby ensuring that it provides you with long and satisfactory service.

When unpacking, check for any damage that may have occurred in transit and notify your CLARKE dealer immediately should any be apparent. Confirm against the inventory on pages 4-6 that all items are present.



Product Dimensions (D x W x H)	640 x 1530 x 844 mm overall
Weight	30 kg
Weight loading	Top bench - 200kg Shelf - 100kg Drawer - 10kg
Worktop dimensions	1400 x 510 mm
Drawer dimensions (H x W x D)	70 x 365 324mm

---

## GUARANTEE

---

This product is guaranteed against faulty manufacture for a period of 12 months from the date of purchase. Please keep your receipt which will be required as proof of purchase.

This guarantee is invalid if the product is found to have been abused or tampered with in any way, or not used for the purpose for which it was intended.

Faulty goods should be returned to their place of purchase, no product can be returned to us without prior permission.

This guarantee does not effect your statutory rights.

---

## GENERAL SAFETY PRACTICES

---

1. Keep the work area clean and tidy.
2. Dress appropriately - **Do not** wear loose clothing or jewellery. Tie long hair out of the way.
3. Keep children and visitors away - **Do not** let children handle the components.
4. **Do not** overreach - Keep proper footing and balance at all times.







---

## TOOLS REQUIRED

---

- Hex key (4mm)
- X-head screwdriver
- Standard screwdriver

# PACK CONTENTS

A) Side piece (pair)	
B) Left leg frame	
C) Right leg frame	
D) Shelf base	
E) Drawer holder (left and right handed pair)	
F) Worktop	

G) Drawer front



H) Drawer side



I) Drawer base



J) Drawer rear



K) Outer Drawer Runner(pair)



L) Inner Drawer Runner (pair)



M) Steel locating dog (x4)

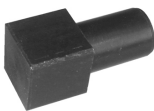

N) Woodworkers vice assembly(pair)



P) Workbench pegs (x 4)



Q) Shelf machine screw & barrel nut s(x4)



R) Wood screw



(Long (x8)/Short) (x6)s

S) Machine screws (Long (x4)/Short (x4))



## ASSEMBLY

1. Insert the barrel nuts (Q) into the side pieces (A).

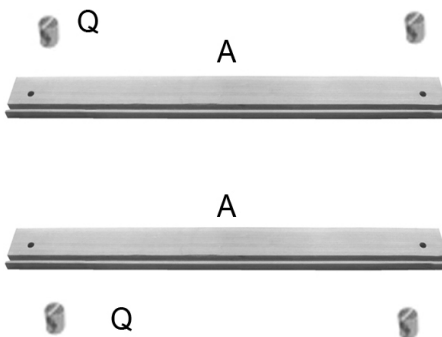

2. Use the machine screws (Q) to secure both leg frames (B and C) to one of the side pieces.

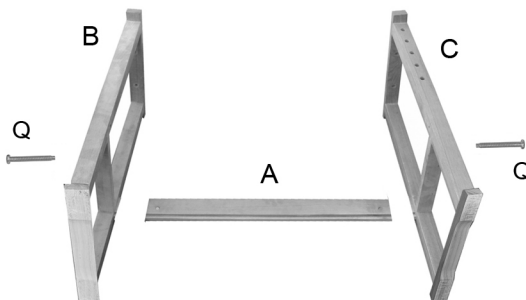

At this stage the frame should look like this.

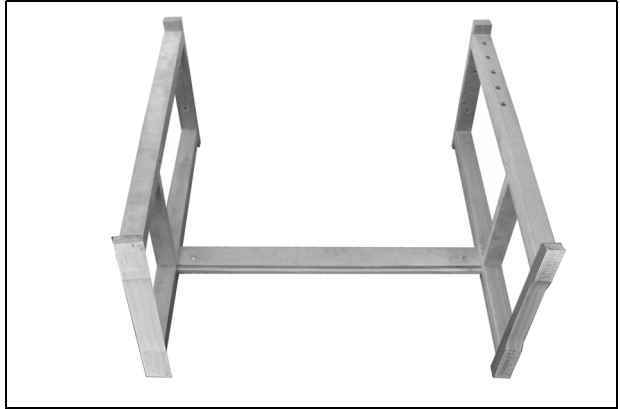

- Slide the shelf base (D) into the grooves in the side pieces as shown.

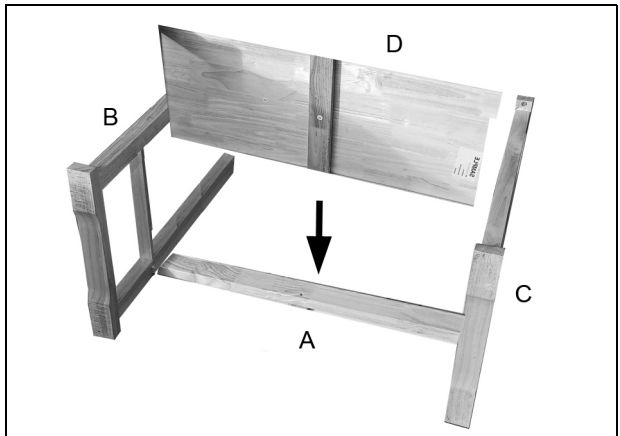

- Secure the second side piece to the two leg frames using machine screws (Q) and barrel nuts.

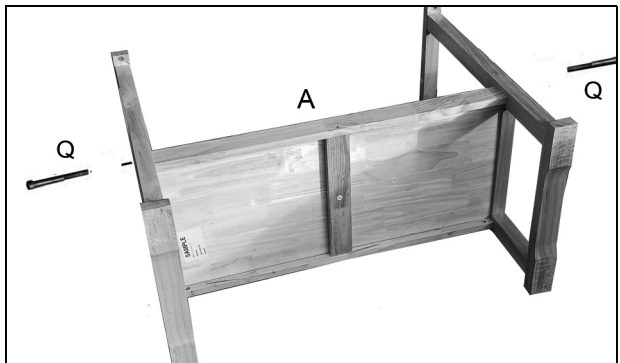

At this stage the frame should look like this.



The outer drawer runners (K) need to be fitted to both the drawer holders (E).

- The inner runners (L) will be fitted to the side panels of the drawer.

Identify which runner is for the drawer (inner) and which is for the holders (outer). Ensure the outer drawer runners are screwed to the drawer holders using the short wood screws supplied. Slide the drawer runner left and right to access the fixing points.

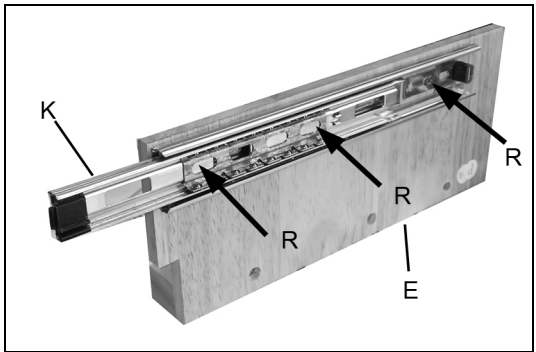

5. Lay the workbench upside down.

6. Fix the drawer holders (E) into place using the short machine screws (S).

- The drawer holder panels should be labelled L and R.

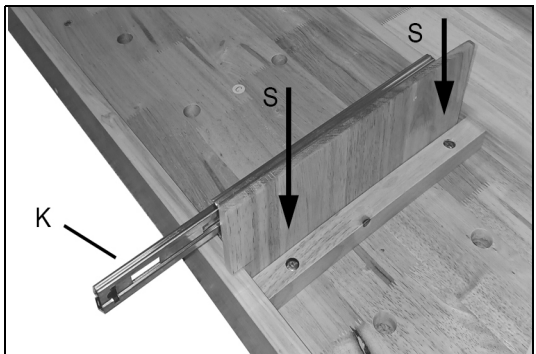



7. Fit the legs into position and secure the assembly using long machine screws (S).



8. Turn the assembly the right way up.
9. Take the drawer side panels (H) and determine which is left and right and therefore which is the outside surface of each panel.

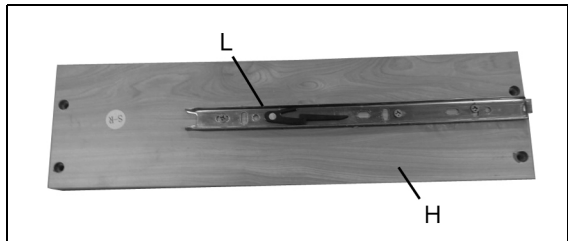

10. Fix the inner draw runners (L) to the inside faces of the panels using the short wood screws (R).
11. Assemble the drawer as follows.

## DRAWER ASSEMBLY

11.1



Fit the rear of the drawer (J) to one of the drawer sides (H) and fix into position using the long screws (R) provided.

11.2



Fit the other side (H) as shown.

11.3



Rotate the drawer and slide the drawer base (I) into position.

11.4



Fix the drawer front (G) as shown above.  
The drawer is now complete.

12. Slide the drawer along its runners until it clips into place.

- A plastic clip in each runner facilitates removal of the drawer in future.

13. Fit both vice assemblies as shown, inserting the guides and screw thread into the sockets in the bench and screwing home as required.



14. Fit the locating pegs and dogs into their locating holes as required.

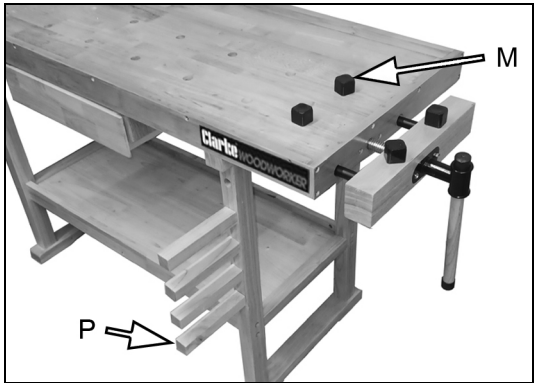

# A SELECTION FROM THE VAST RANGE OF

# Clarke®

## QUALITY PRODUCTS



### AIR COMPRESSORS

From DIY to industrial, Plus air tools, spray guns and accessories.

### GENERATORS

Prime duty or emergency standby for business, home and leisure.

### POWER WASHERS

Hot and cold, electric and engine driven - we have what you need

### WELDERS

Mig, Arc, Tig and Spot. From DIY to auto/industrial.

### METALWORKING

Drills, grinders and saws for DIY and professional use.

### WOODWORKING

Saws, sanders, lathes, mortisers and dust extraction.

### HYDRAULICS

Cranes, body repair kits, transmission jacks for all types of workshop use.

### WATER PUMPS

Submersible, electric and engine driven for DIY, agriculture and industry.

### POWER TOOLS

Angle grinders, cordless drill sets, saws and sanders.

### STARTERS/CHARGERS

All sizes for car and commercial use.

## PARTS & SERVICE:

## 0208 988 7400

### Parts Enquiries

[Parts@clarkeinternational.com](mailto:Parts@clarkeinternational.com)

### Servicing & Technical Enquiries

[Service@clarkeinternational.com](mailto:Service@clarkeinternational.com)

SALES: UK 01992 565333 or Export 00 44 (0)1992 565335

**Clarke** INTERNATIONAL Hemnall Street, Epping, Essex CM16 4LG  
[www.clarkeinternational.com](http://www.clarkeinternational.com)